

ioLogik E2210

Active Ethernet micro controller with 12 digital inputs and 8 digital outputs

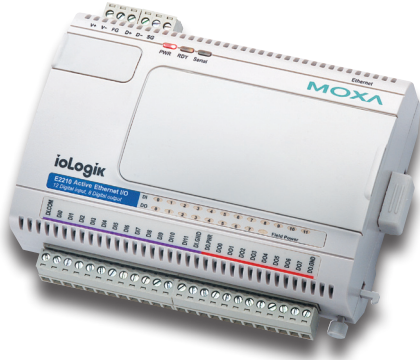

- > Front-end intelligence that supports 24 Click&Go™ rules
- > Active Messaging with real-time stamp, including SMS, SNMP Trap with I/O status, TCP, and email
- > Supports SNMPv1/v2c/v3 protocol
- > I/O peer-to-peer function
- > Built-in web console
- > PC utility: Auto detection of installed modules
- > Windows/WinCE VB/VC.NET and Linux C APIs



Introduction

Moxa's ioLogik E2210 is a new type of active micro controller that can be used as an RTU (Remote Terminal Unit). Active Ethernet micro controllers are a kind of PC-based data acquisition and control device that use proactive, event-based reporting to control I/O devices. Unlike traditional RTUs, which are passive and must poll for data, Moxa's Active OPC Server makes seamless connection with SCADA systems

a reality. In addition, SNMP is used for communicating with an NMS (Network Management System) for IT field users. The I/O status of an Active Ethernet micro controller can be reported and controlled automatically on-site based on user specified conditions. This report-by-exception approach, which is new to PC-based monitoring, requires far less bandwidth than traditional polling methods.

Specifications

LAN

Ethernet: 1 x 10/100 Mbps, RJ45

Protection: 1.5 KV magnetic isolation

Protocols: Modbus/TCP, TCP/IP, UDP, DHCP, Bootp, SNMP, HTTP, CGI, SNTp

Serial Communication

Interface: RS-485-2w: Data+, Data-, GND

Serial Line Protection: 15 KV ESD for all signals

Serial Communication Parameters

Parity: None

Data Bits: 8

Stop Bits: 1

Flow Control: None

Baudrate: 1200 to 115200 bps

Protocol: Modbus/RTU

Digital Input

Channels: 12, source type

Sensor Type: NPN, Dry contact

I/O Mode: DI or Event Counter (up to 900 Hz)

Dry Contact:

- Logic 0: short to GND
- Logic 1: open

Wet Contact: (source type)

- Logic 0 (On): 0 to 3 VDC
- Logic 1 (Off): 10 to 30 VDC

Common Type: 12 points per COM

Isolation: 3K VDC or 2K Vrms

Counter/Frequency: 900 Hz

Digital Filtering Time Interval: Software selectable

Over-voltage Protection: 36 VDC

Digital Output

Channels: 8, sink type, 36 VDC, 200 mA

I/O Mode: DO or Pulse Output (up to 100 Hz)

Pulse Wave Width/Frequency: 10 ms/100 Hz

Over-voltage Protection: 45 VDC

Over-current Limit: 400 mA (typical)

Over-temperature Shutdown: 175°C (min.)

Output Current Rating: Max. 200 mA per channel

Isolation: 3K VDC or 2K Vrms

Power Requirements

Power Input: 24 VDC nominal, 12 to 36 VDC

Power Consumption: 282 mA typical @ 24 VDC

Physical Characteristics

Wiring: I/O cable max. 14 AWG

Dimensions: 115 x 79 x 45.6 mm (4.53 x 3.11 x 1.80 in)

Weight: under 250 g

Environmental Limits

Operating Temperature:

Standard Models: -10 to 60°C (14 to 140°F)

Wide Temp. Models: -40 to 75°C (-40 to 167°F)

Storage Temperature: -40 to 85°C (-40 to 185°F)

Ambient Relative Humidity: 5 to 95% (non-condensing)

Regulatory Approvals

EMI: FCC Part 15, CISPR (EN55022) class A

EMS: IEC 61000-4, IEC 61000-6

Safety: UL508

Shock: IEC 60068-2-27

Freefall: IEC 60068-2-32

Vibration: IEC 60068-2-6

Note: Please check Moxa's website for the most up-to-date certification status.

Warranty

Warranty Period: 5 years

Details: See www.moxa.com/warranty

Dimensions

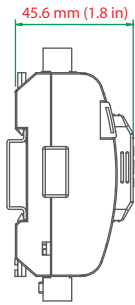

Side View

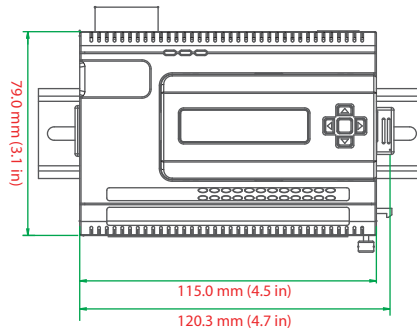

Front View

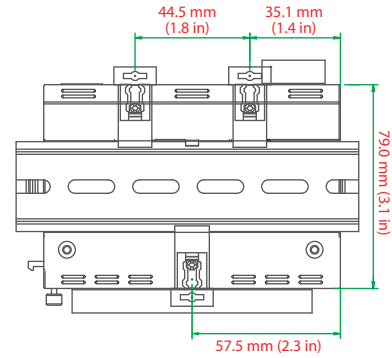

Rear View

: Ordering Information

Available Models

ioLogik E2210: Active Ethernet micro controller with 12 digital inputs and 8 digital outputs, -10 to 60°C operating temperature

Accessories (can be purchased separately)

LDP1602: LCD module with 16 x 2 text and 5 buttons

LDP1602 LCD Module

Snap-on module for the ioLogik E2200/R2100 series



- > Hot-pluggable display module for ioLogik Active Ethernet micro controllers
- > Easy, portable configuration kit for IP display and configuration
- > Direct display for analog value and digital input, counter status
- > No battery required (powered through the I/O)



Installing the LCD Module

1. Remove the ioLogik's top cover.

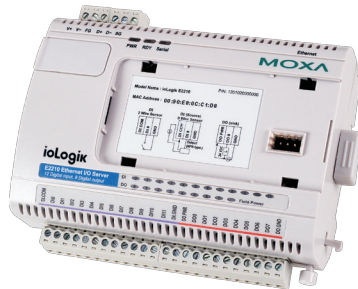

2. Plug in the LCD module.

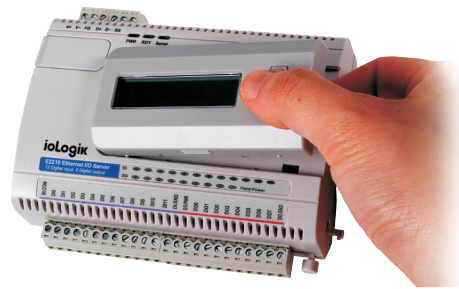

3. Check and configure the IP address.

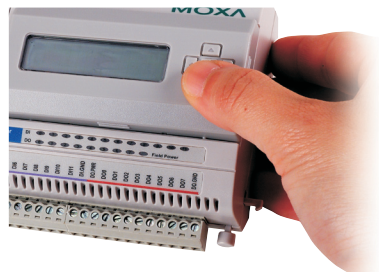

4. Check IP and I/O status.

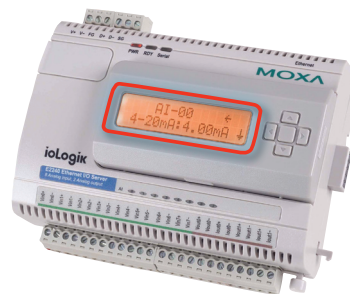

Specifications

LCD Screen: 16 x 2 text display (in English)
Operating Temperature: 0 to 55°C (32 to 131°F)

Storage Temperature: -20 to 70°C (-4 to 158°F)
Ambient Relative Humidity: 5 to 95% (non-condensing)

Ordering Information

LDP1602: LCD module with 16 x 2 text display and 5 buttons